

PLANOMAT XM 408

UNIVERSALLY DESIGNED,
READY FOR THE FUTURE



PLANOMAT XM 408

DIMENSIONS

- Working area: 400 x 800 mm
- X-axis (longitudinal stroke): 900 mm
- Y-axis (vertical stroke): 500 mm
- Z-axis (transverse stroke): 360 mm

HARDWARE

- Modular machine concept
- Design characteristics: very high rigidity, minimum vibrations, minimum thermal influences
- Precision linear guideways
- High quality, recirculating ball screws
- Spindle power: 8 kW
- C.O.R.E. panel

SOFTWARE

- Pre-programmed grinding and dressing cycles
- Intuitive operation
- C.O.R.E. OS operating system
- Digital Solutions

« The use of high-quality components from the modular system of our PLANOMAT machine generation ensures high precision and a long service life. »



YOUR BENEFIT

The PLANOMAT XM 408 is more than just a machine tool – it is an investment that pays off in the long term. It combines maximum precision with flexible application and, with modern technology and worldwide service, ensures your productivity for the future.

- Repeatability – consistent quality throughout the entire service life
- Precision – accurate results for every workpiece
- Versatility – flexible software and intuitive operation
- High availability – robust construction and worldwide service, including digital
- Strong partnership – UNITED MACHINING SOLUTIONS (grinding, milling, EDM)



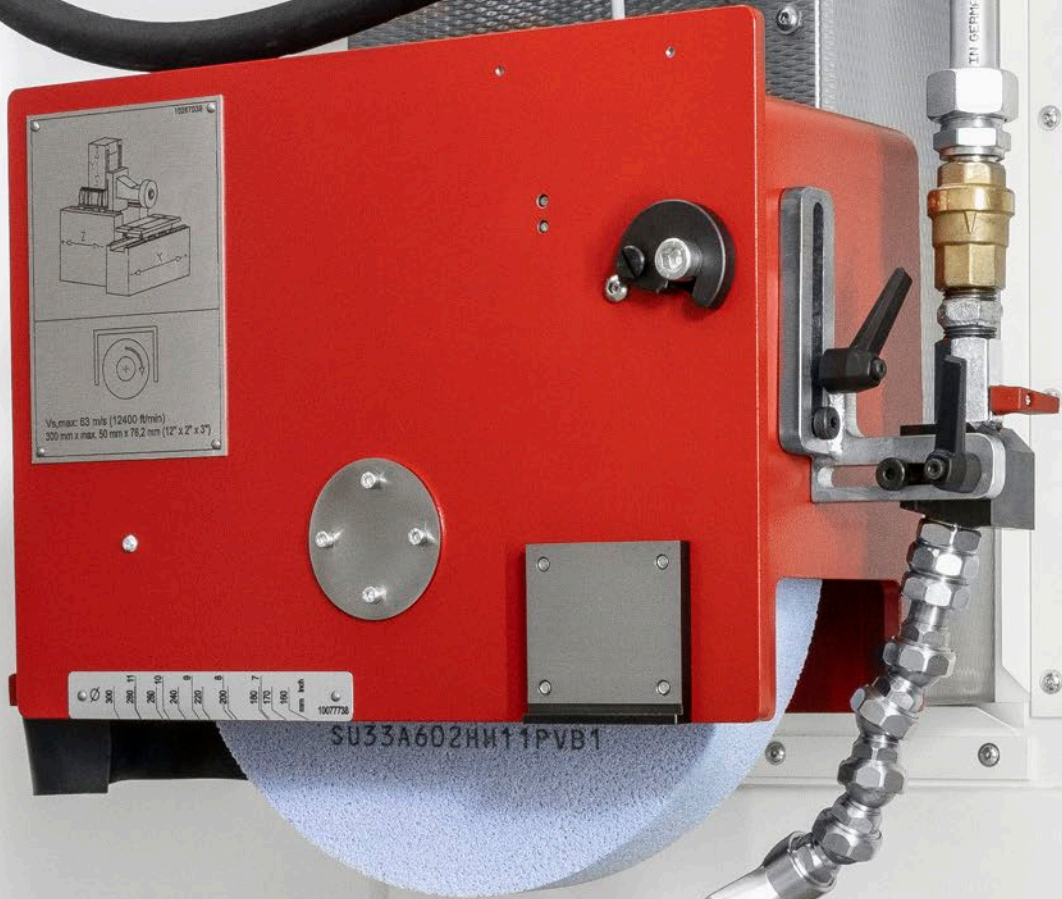

APPLICATION

611065
Type: 1120-40/70-13 BH-3
Nr: 611065 EP360 150kg
Blöhm Mat. Nr: 30055408

VERSATILE AND RELIABLE IN EVERY APPLICATION

The PLANOMAT XM 408 is the solution for demanding machining tasks – from complex shapes to high-precision parts in a wide variety of materials.

Whether deep grinding or multi-stage production in a single setup: with its flexibility and efficiency, it sets standards in surface and profile grinding. A powerful drive and state-of-the-art control technology guarantee maximum precision and reliability.

Our application engineers work with you to develop customized solutions for your individual requirements.

Tools

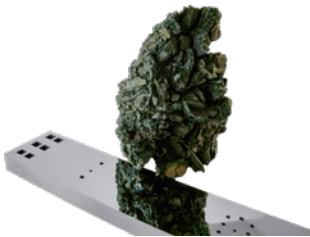

Dies



Blades / Knives



Fixtures / Chucks

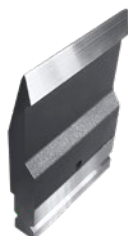
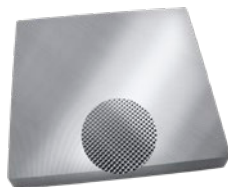

REPEATABILITY – CONSISTENT THROUGHOUT THE ENTIRE SERVICE LIFE

3-point design for long-term repeatability

The PLANOMAT XM 408 is based on a proven 3-point design that guarantees maximum stability throughout its entire service life. The heavily ribbed machine bed retains its geometry permanently. With a dead weight of approx. 5 tons and an inherently rigid structure, the machine ensures thermal stability between the machine table and grinding wheel – even with changing ambient temperatures.

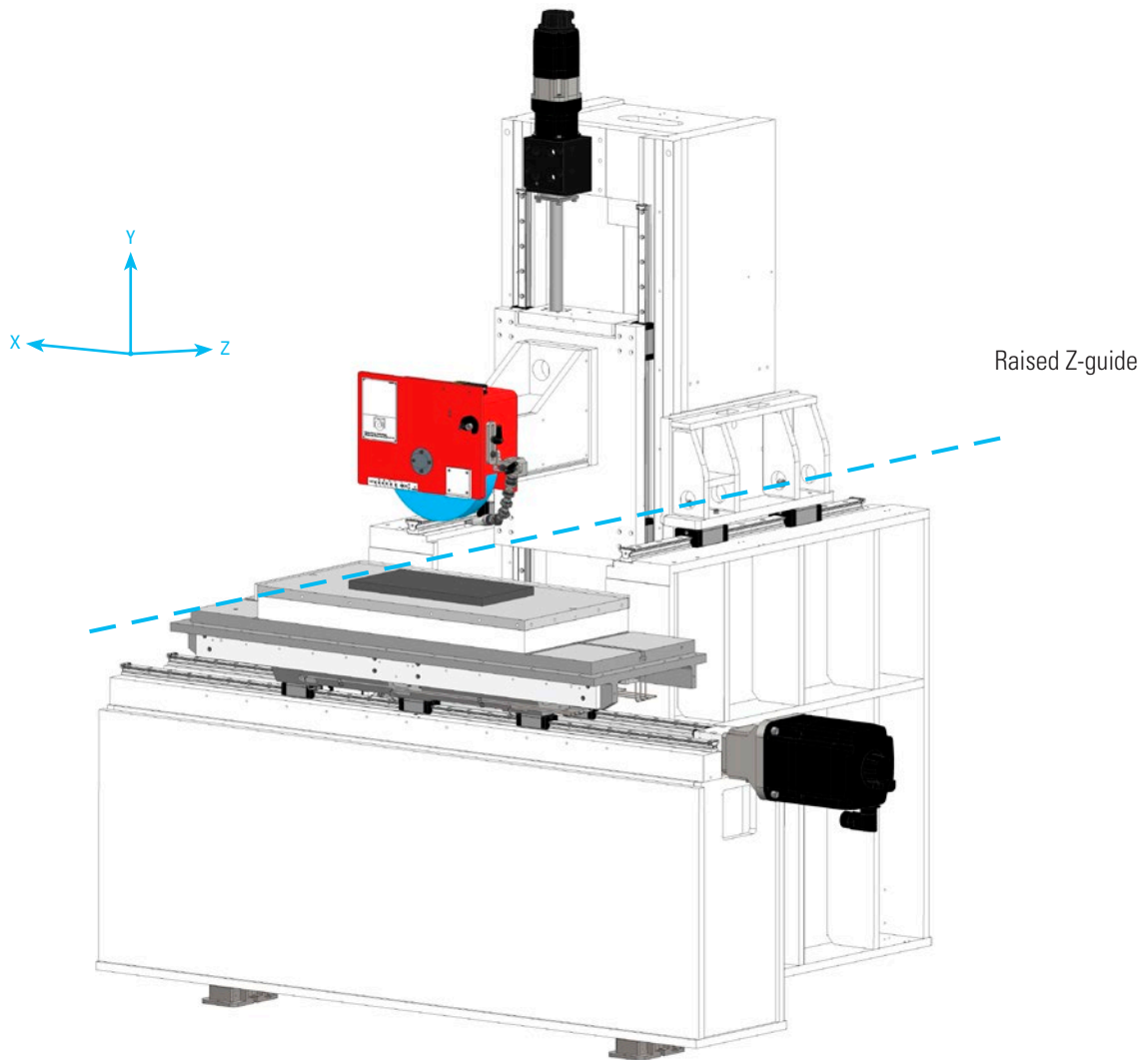
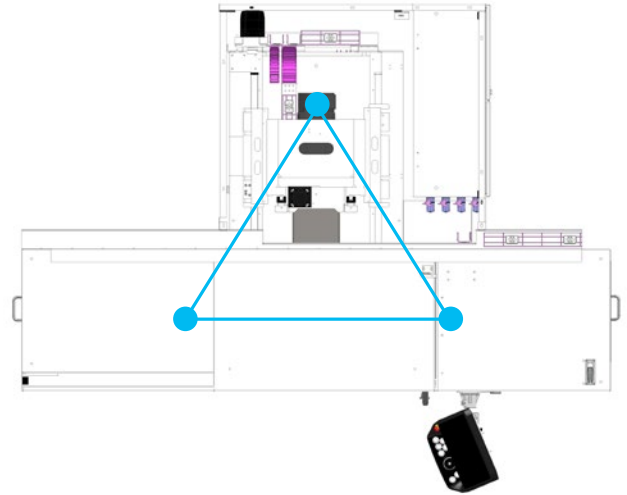

PRECISION – ACCURATE RESULTS FOR EVERY WORKPIECE

Raised Z-guide for maximum precision

The unique design with raised Z-guide significantly reduces bending forces on the column. Unlike C-column designs, which can bend during grinding, the PLANOMAT XM 408 remains dimensionally stable. The high dynamic rigidity ensures accurate results – even under changing conditions and with demanding workpieces.

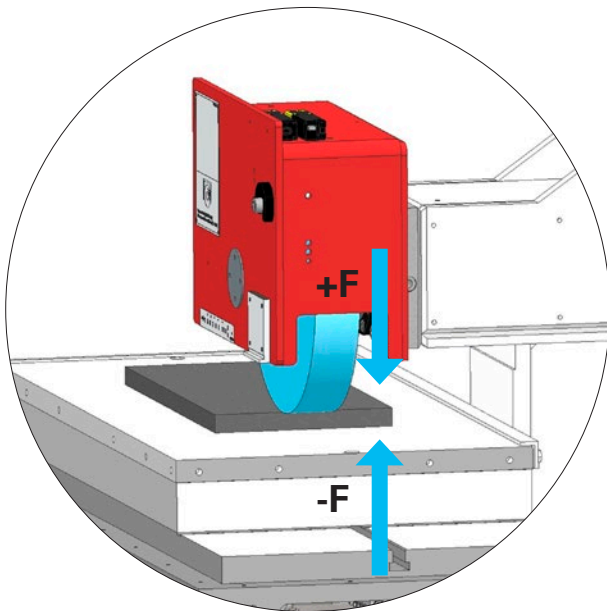

- Consistent accuracy even with temperature fluctuations
- Consistent precision throughout the entire service life
- Stability thanks to 3-point construction and ribbed machine bed
- Perfect flatness across the entire workpiece
- Clean edges without breakouts
- Uniform grinding pattern for high-quality surfaces

C.O.R.E. – CUSTOMER ORIENTED REVOLUTION

With C.O.R.E., we make your production fit for the digital future.

The C.O.R.E. system from UNITED GRINDING is a future-oriented hardware and software platform that takes the operation, networking and digitalization of machine tools to a new level. C.O.R.E. was developed to make our machines and your production environment fit for the digital industry of tomorrow. Operation is simple and intuitive via the multi-touch display, with a modern and customizable user interface. Thanks to the standard-

ized hardware and software architecture, all UNITED GRINDING machines equipped with C.O.R.E. technology are network-compatible and can be easily integrated into digital factories. All common interface formats are supported. C.O.R.E.'s modern IoT technology core also enables data-based value-added services and integration and communication with cloud-based customer platforms.



C.O.R.E. ARCHITECTURE

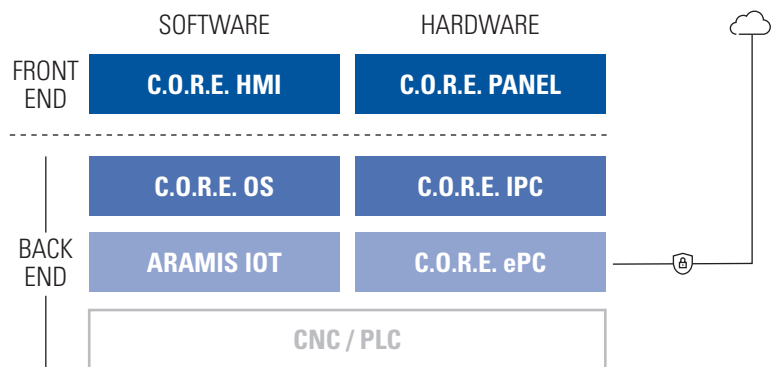

C.O.R.E. PANEL & HMI – NEXT-GENERATION MACHINE OPERATION

Like a large smartphone

With C.O.R.E., UNITED GRINDING has redefined the interaction between man and machine tool. Modern design combined with the most advanced technology to meet the operator requirements of tomorrow. The 24" multi-touch display enables navigation by touch and swipe gestures, similar to a smartphone. The uniform HMI for all UNITED GRINDING machines facilitates set-up, operation and general maintenance. Customizable user roles enable the display and restriction to role-relevant information and thus increase user-friendliness and safety. With the integrated front camera on the panel, assistance can be provided directly at the machine via Remote Service.

Future-proof

The digital capabilities of your machine with C.O.R.E. technology continue to grow. The C.O.R.E. HMI is continuously being expanded with new functionalities, widgets and apps to make it even more user-friendly and customizable. The arrangement, type and size of the tiles on the HMI can be customized so that every machine operator always has the information that is important to him or her at a glance.

In future, new software updates and functionalities will be easy to install via the customer portal, so you will always be up to date.



5.8

Technical data

- 24" Full HD Multitouch-Display
- Override rotary switch with cycle start
- Standardized function keys
- Integrated 2-hand start
- Electronic key system (RFID)
- Integrated front camera
- Tilt adjustment

INTUITIVE OPERATION

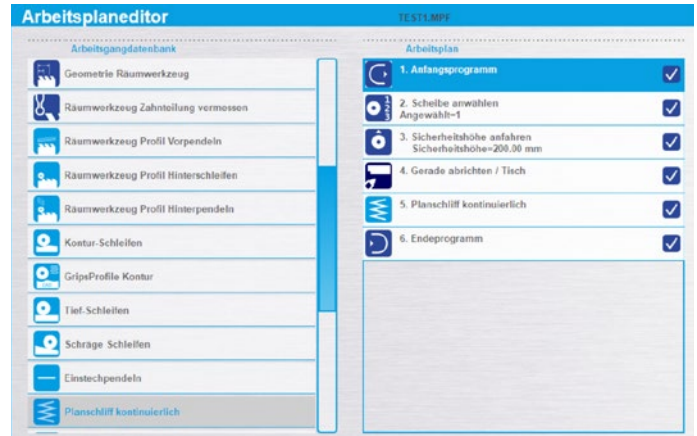

Easy + Fast program creation via drag and drop in the working plan editor

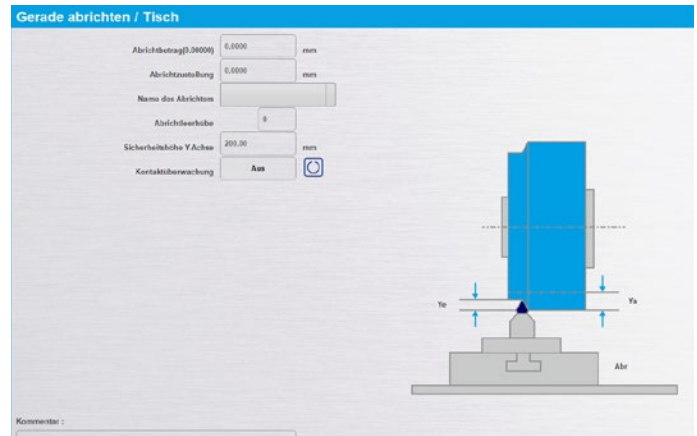

Quick adjustment of dressing cycles using parameters

The convenient solution for every grinding task

The best machines in their performance class offer more than just technically sophisticated components. Their high performance is achieved through the use of perfectly coordinated software and technology.

The Siemens Sinumerik One CNC control with graphical user interface guarantees optimal processes. Menu-driven grinding and dressing cycles make programming considerably easier.

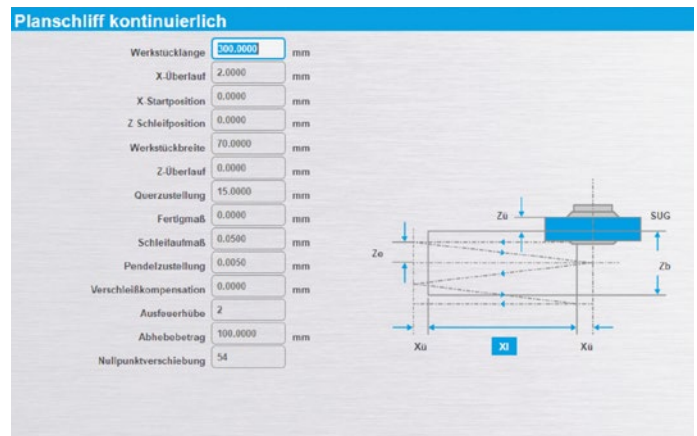

Quick adjustment of grinding cycles using parameters

FLEXIBLE GRINDING TASKS

The machine control system offers standard grinding cycles for all flat, surface, and face grinding tasks. In addition, there is comprehensive tool management with up to 50 grinding wheels and 15 dressing tools.

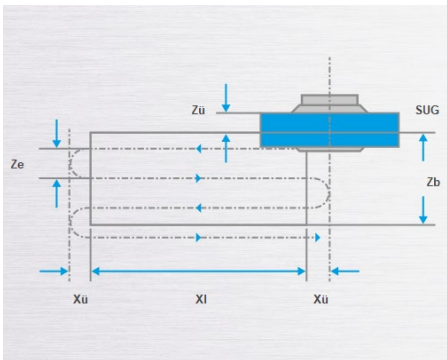

Intermittent surface grinding

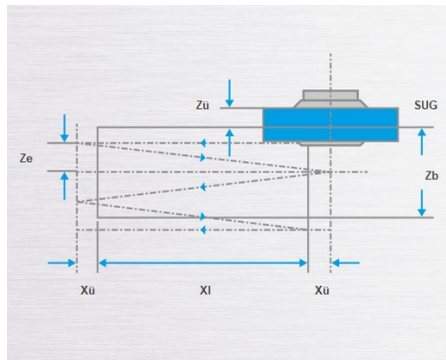

Continuous surface grinding

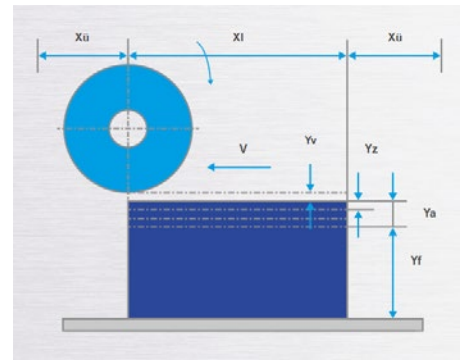

ECO surface grinding

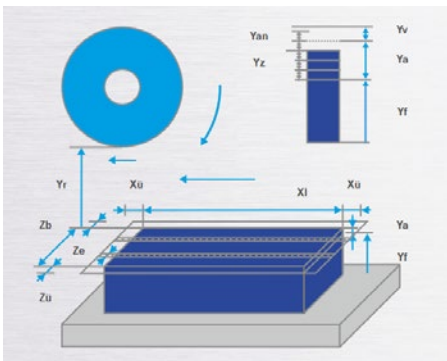

Plunge grinding

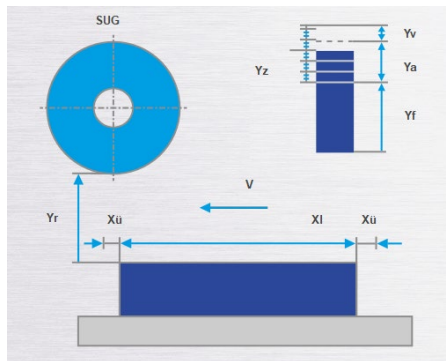

Creed feed grinding

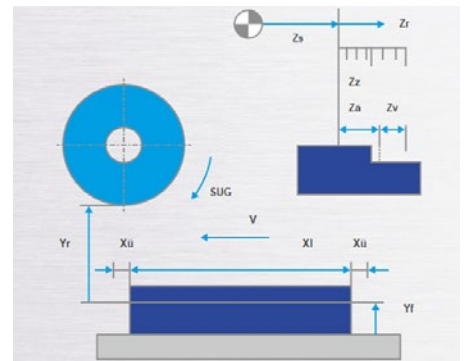

Faces grinding

EXTENDED GRINDING TASKS

Extended grinding cycle interpolation

These enable a wide range of machining operations through the interpolation of multiple machine axes. These include deep grinding at an angle, grinding convex or concave radii, and path-guided deep grinding in the X/Y plane.

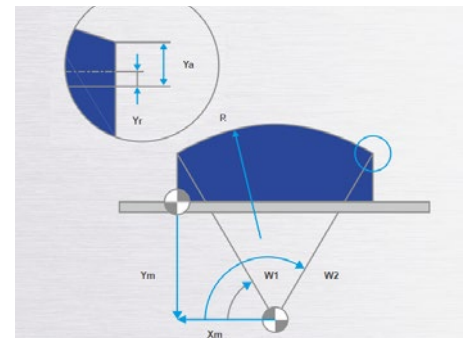
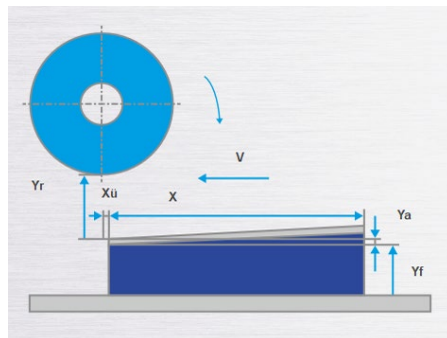
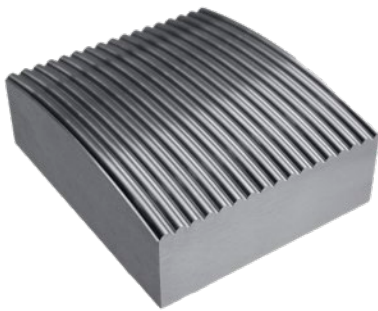

Profile grinding with GripsProfile

The GripsProfile option is installed on the machine control system. With a software dongle, it can also be used on an external PC if required.



Parallel-axis dressing



Contour-parallel dressing



Simulation

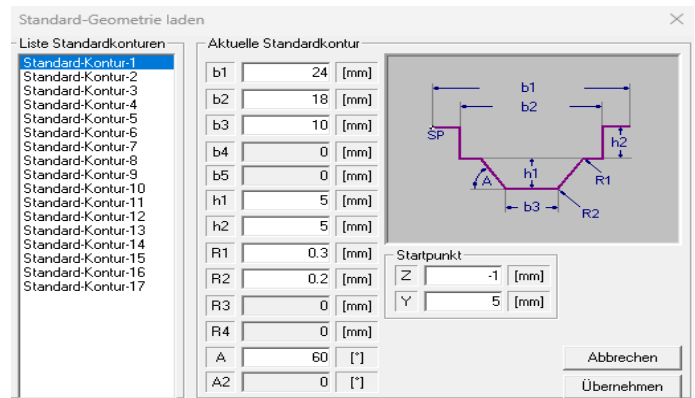

Overview of functions

- 17 predefined standard contours
- Import of DXF contours
- CAD module for free geometries
- Selection of various dressing and pre-dressing tools
- Dressing logic for contour, layer, and axis-parallel dressing
- Automatic generation of path grinding programs in
- X/Y or Y/Z direction
- Automatic creation of dressing programs
- Simulation of contour creation with integrated collision checking

AUTOMATED MEASURING PROBES FOR PRECISE, RELIABLE GRINDING

For safe and automated processes – such as multiple clamping or finish grinding of complex workpieces – the PLANOMAT XM 408 offers an integrated measuring probe system. The measuring probe is mounted on the left side of the grinding wheel guard and extends pneumatically; the measuring ball is automatically cleaned via an air nozzle. Fully integrated into the grinding cycle, the system enables workpiece detection and pre-positioning along the X, Y, and Z axes. Thanks to high repeat accuracy, workpieces can be automatically ground to their final height (Y axis).

- Automated processes for multiple clamping
- Reliable detection of workpiece position
- Automatic grinding of workpieces to final height (Y-axis)
- Flexible execution of a wide variety of measuring tasks

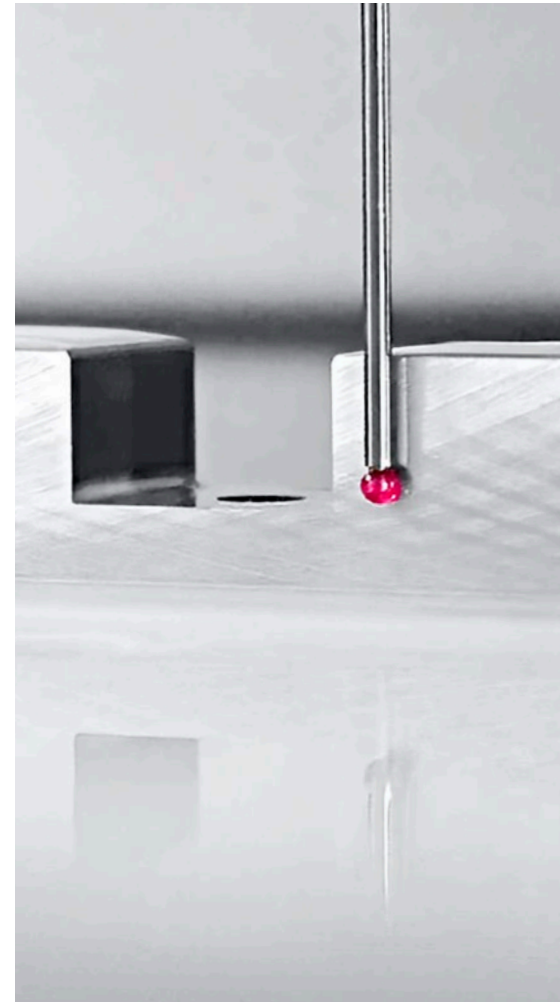
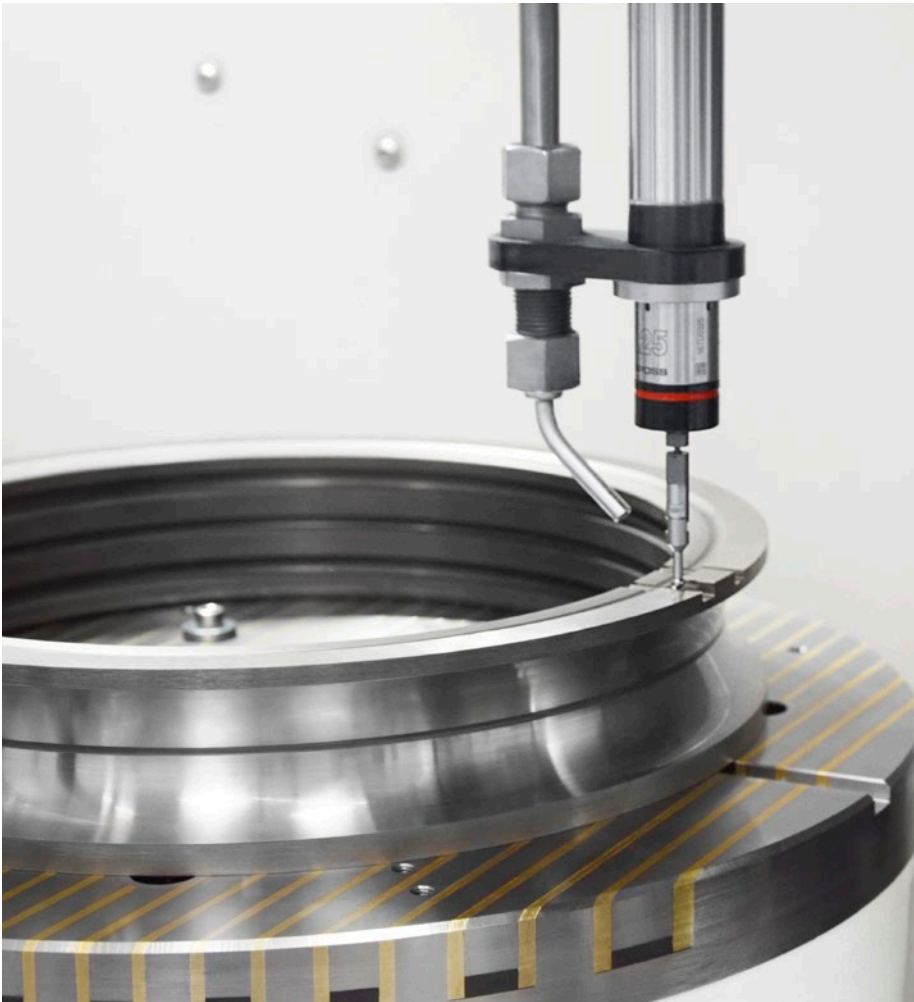

DRESSING SYSTEMS – MAXIMUM FLEXIBILITY FOR COST-EFFECTIVE MANUFACTURING

PA-T130 swiveling dressing device

High-end solution for continuous, path-controlled dressing. Offers maximum flexibility for complex contour grinding as well as automatic setup and measurement of the diamond wheel.

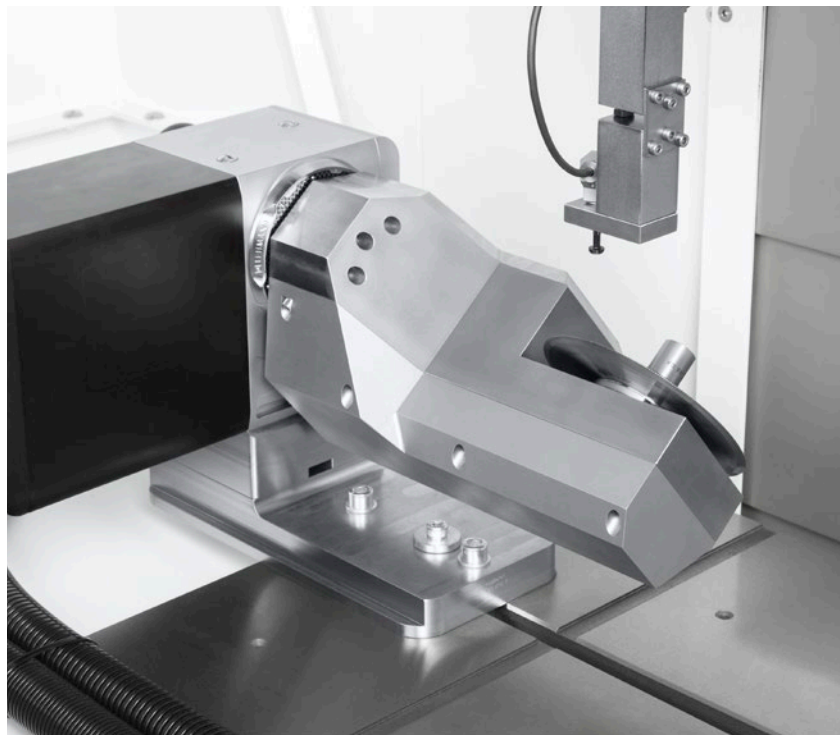

Diamond holder

Simple solution for straight dressing of grinding wheels. Available in flexible heights of 90, 150, or 300 mm.



Tilting profile dresser

For face, end, and profile dressing. The pneumatically operated swiveling mechanism reliably prevents collisions with the grinding wheel, protective cover, and dresser.

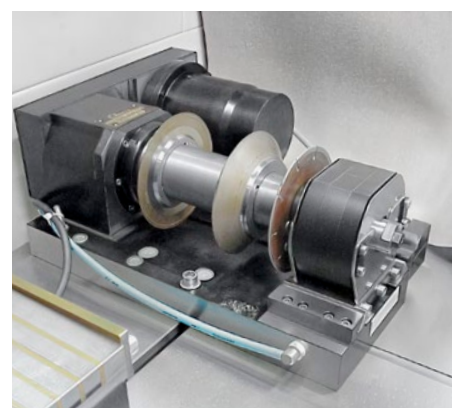

PA-T200S dressing device

Universal system for diamond form rolls and pre-profiling tools for path-controlled dressing. Ideal for versatile and precise applications.

DIGITAL SUPPORT: ENSURE PRODUCTIVITY, AVOID DOWNTIME

The PLANOMAT XM 408 is ready for digital manufacturing. The OPC UA umati interface allows machine statuses, alarms, and messages to be called up at any time—transparently and in real time.

The integrated HEALTH MONITORING system uses a digital fingerprint as a reference. By comparing this with live data, deviations on the axes are detected at an early stage – failures can be avoided and maintenance can be planned in a targeted manner.

With Remote Service, machine data and error logs are available directly via the C.O.R.E. Panel or via smartphone – for fast and professional support, anywhere and anytime.

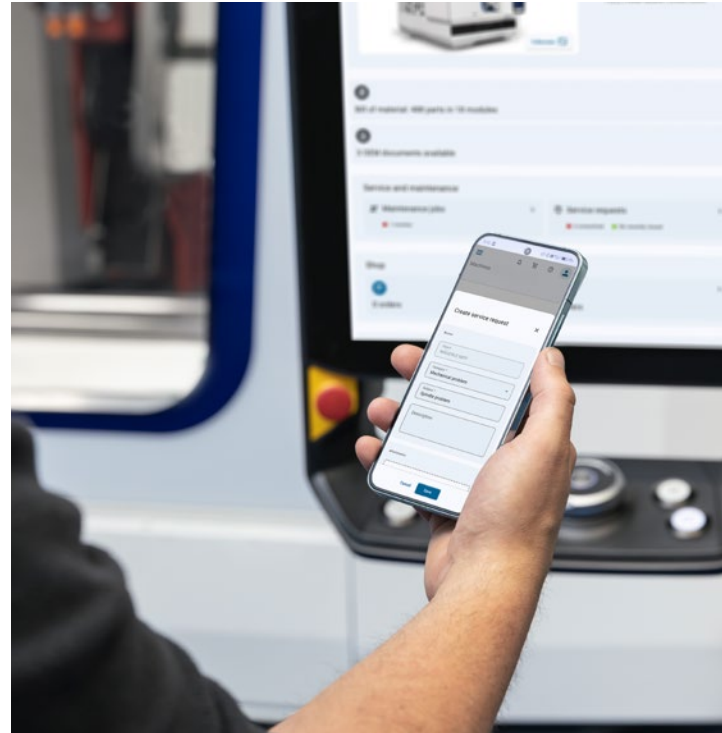

- Transparent availability through OPC UA umati
- Early detection of deviations with health monitoring
- Predictive maintenance instead of unplanned downtime
- Fast support through remote service

MAINTENANCE-FRIENDLY DESIGN

A large sliding door provides excellent access to the work area. The compact control cabinet is integrated directly into the enclosure. The work area enclosure is designed as a sturdy welded construction. All units and components are centrally located and easily accessible.

In addition, maintenance doors on both sides allow quick access. This means that regular work can be carried out efficiently and in a time-saving manner.

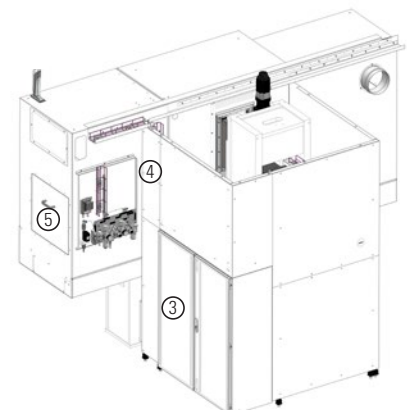
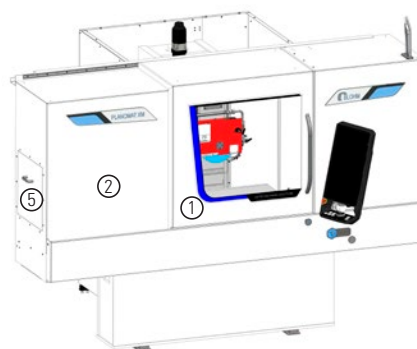

- ① Workspace door
- ② Workspace enclosure
- ③ Control cabinet
- ④ Cable routing
- ⑤ Maintenance doors

TECHNICAL DATA

PLANOMAT XM 408

Working range	400 × 800 mm
Distance table to spindle center	600 mm
X-axis Longitudinal stroke	900 mm
Travel speed	0 – 30,000 mm/min
Y-axis Longitudinal stroke	500 mm
Travel speed	0 – 3,750 mm/min
Z-axis Longitudinal stroke	360 mm
Travel speed	0 – 3,750 mm/min
Grinding wheel dimensions (d x w x bore)	300 × 50 × 76.5 mm
Power grinding wheel drive	8 kW
Cutting speed	63 m/s ²
Machine weight, incl. electrical cabinet	5,500 kg

Technical specifications subject to change

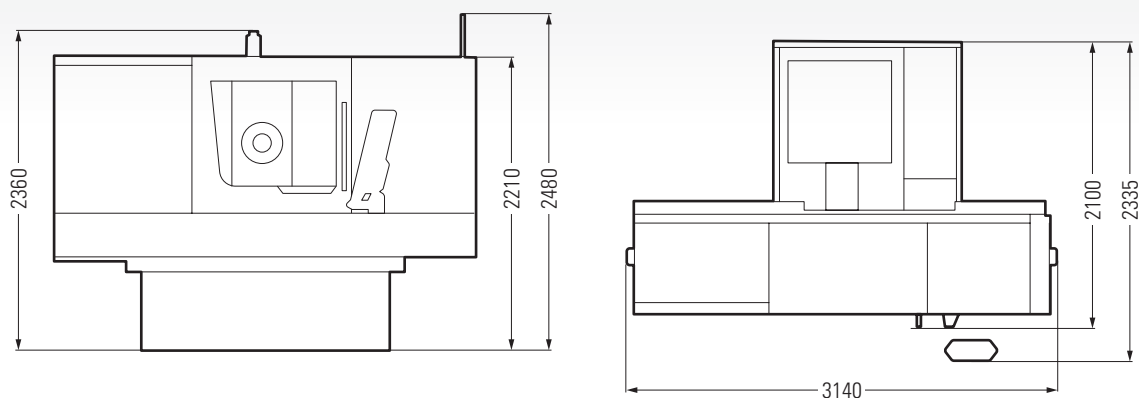

PLANOMAT XM 408

Dimensions in mm. Options, accessories, or doors in the open position may increase the dimensions of the machine.
Subject to change without notice due to technical progress and errors excepted. Information provided without guarantee.

WE ARE HERE FOR YOU!

Our products are designed to meet customer demands for as long as possible, they are intended to operate efficiently, reliably, and be available at any time.

From “Start up” through to “Retrofit” – our Customer Care is there for you throughout the working life of your machine. For this reason, you can rely on competent HelpLines worldwide and Service Engineers near you:

- We will provide you with fast, straight-forward support.
- We will help to increase your productivity.
- We work professionally, reliably and transparently.
- We will provide a professional solution to your problems.



Start up
Commissioning
Extension of the guarantee



Qualification
Training
Product support



Prevention
Maintenance
Inspection



Service
Customer service
Customer advice
Helpline



Digital Solutions
Remote Service

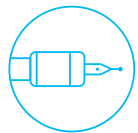

Material
Spare parts
Replacement parts
Accessories



Rebuild
Machine overhauling
Refurbishing of assemblies



Retrofit
Conversions
Retrofitting parts

DIGITAL SOLUTIONS

Digital Solutions stand for products and services that open up the data space of your machine through IoT-based networking, enable seamless integration across the entire store floor in digital value-added networks and provide data-based value-added services and

digital services – for greater efficiency, productivity and competitiveness. You can find out more about the services of Digital Solutions on our website under the Customer Care section.

CUSTOMER CARE



BLOHM JUNG GMBH

Productivity, performance, and precision—these are the three characteristics that users worldwide associate with flat and profile grinding machines from BLOHM and JUNG. For decades, our machines have been successfully used in a wide variety of applications and under a wide range of conditions. The experience gained from more than 35,000 machines delivered is continuously incorporated into innovations and further developments – with the aim of sustainably increasing our customers' production efficiency.

Our portfolio ranges from surface grinding machines and universal solutions to customer-specific production machines. Our service and tech-

nology specialists accompany our customers throughout the entire life cycle of the machines – from grinding trials and training to maintenance contracts and retrofit projects. Personal, fast, and competent.

In 2008, the two established brands BLOHM and JUNG were merged under the umbrella of Blohm Jung GmbH. Since then, this combined expertise has set new standards in precision, quality, and cost-effectiveness. As part of UNITED MACHINING SOLUTIONS and with a global sales and service network, Blohm Jung GmbH supports its customers worldwide – and is always close at hand.



ABOUT US

UNITED MACHINING SOLUTIONS

UNITED MACHINING SOLUTIONS is one of the largest machine tool manufacturers in the world. With around 5,000 employees at over 50 global production, service and sales locations, UNITED MACHINING SOLUTIONS is close to its customers and highly efficient. The group is organized into two divisions: UNITED GRINDING and UNITED MACHINING.

UNITED GRINDING includes the brands MÄGERLE, BLOHM, JUNG, STUDER, SCHAUDT, MIKROSA, WALTER, EWAG and IRPD. Its technologies include surface and profile grinding machines, cylindrical grinding machines, machines for tool machining and machine tools for additive manufacturing.

The UNITED MACHINING division includes the brands AGIE CHARMILLES, CHARMILLES, MIKRON MILL, LIECHTI, STEP TEC and SYSTEM 3R. It includes machines for EDM (Electrical Discharge Machining), high-speed milling and laser technology as well as spindle production and automation solutions.

“We want to make our customers even more successful”

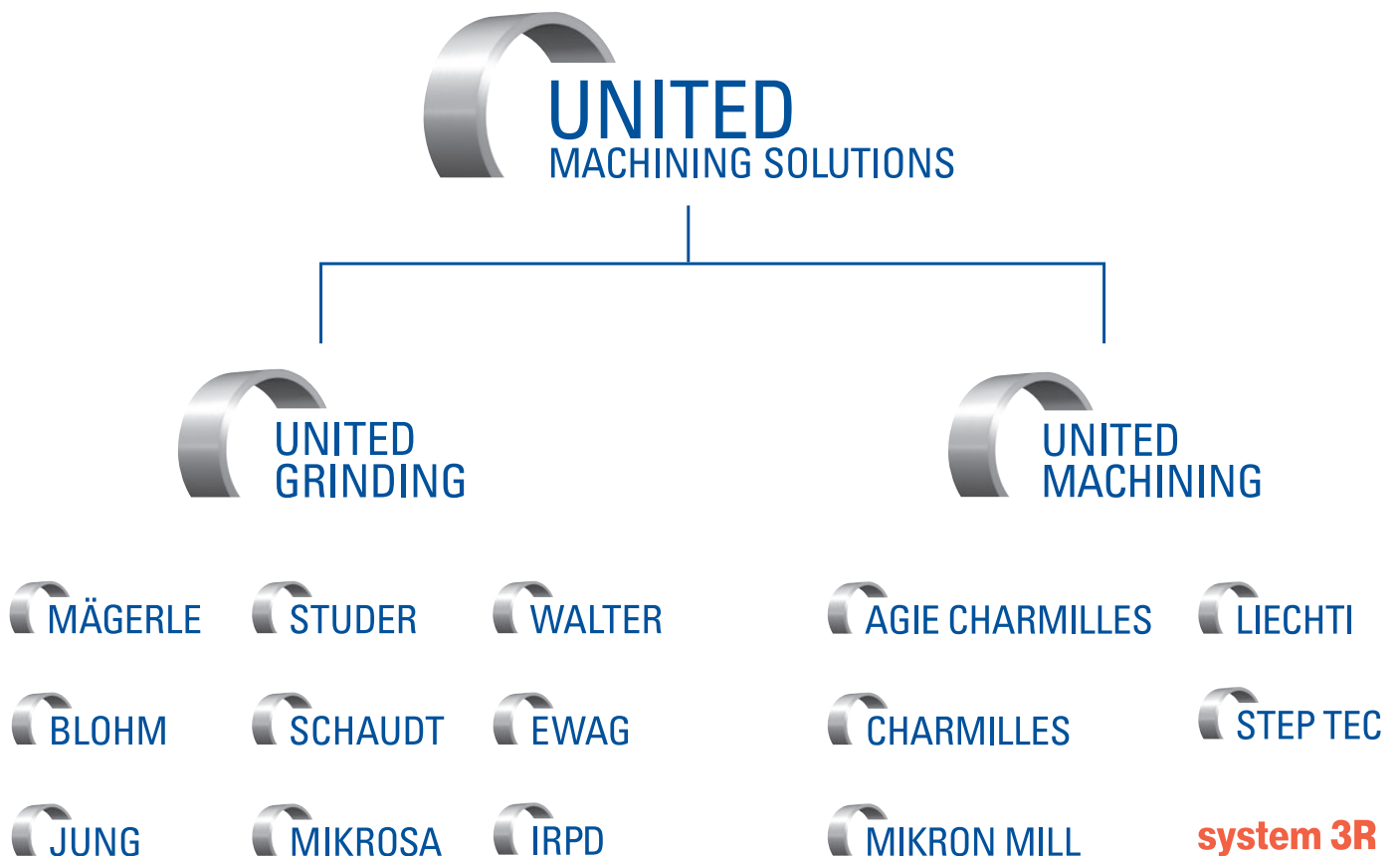



Blohm Jung GmbH

Location Hamburg
Kurt-A.-Körber-Chaussee 63-71 · 21033 Hamburg, Germany
Tel. +49 40 33461 2000
sales-hh@blohmjung.com

Location Göppingen
Jahnstraße 80-82 · 73037 Göppingen, Germany
Tel. +49 7161 6271 800
sales-gp@blohmjung.com

For worldwide contact details, please visit
blohmjung.com

